

This material and the information herein is the property of Fuji Electric Co., Ltd. They shall be neither reproduced, copied, lent, or disclosed in any way whatsoever for the use of any third party, nor used for the manufacturing purposes without the express written consent of Fuji Electric Co., Ltd.

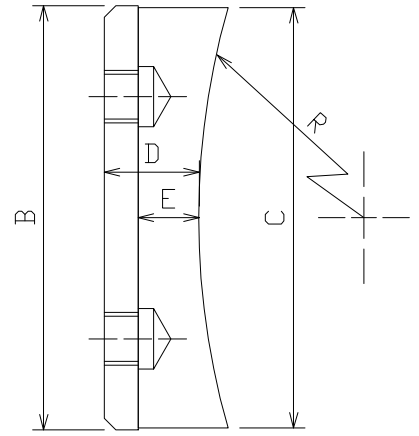
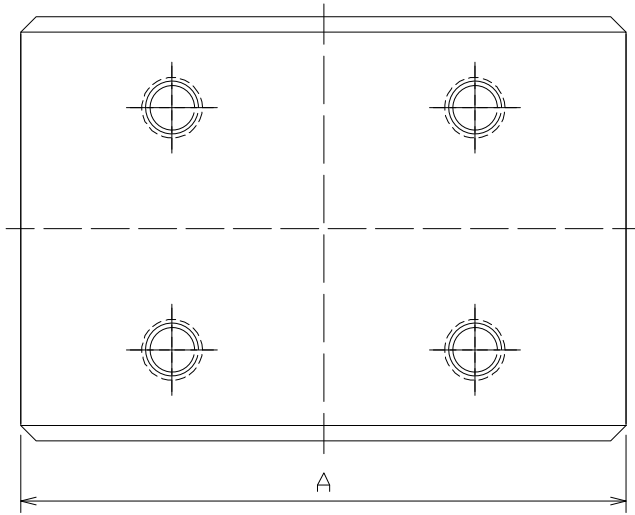

TYPE	A	B	C	D	E	R	PCS/ 1SET
RCa544 - 2 - Liner RCa544C - 2 - Liner	80	56	56	12	7.5	101.5	2
RCa544 - 3,4 - Liner RCa544C - 4 - Liner	90	74	74	13.5	9	127	2
RCa544 - 6,8 - Liner RCa544C - 8 - Liner	140	96	96	17	11	165	2
RCa544 - 10 - Liner RCa544C - 10 - Liner	165	116	116	19	12	203	2
RCa544 - 12,14 - Liner RCa544C - 14 - Liner	216	136	136	23	13	241.5	2
RCa544 - 16,18 - Liner RCa544C - 18 - Liner	280	160	160	25	15	292	2
RCa544 - 20,22,24 - Liner RCa544C - 24 - Liner	356	210	210	31	18	381	2

REVISIONS					DWG.CODE		
REF.					TITLE	TYPE	RCa544, RCa544C
						BRAKE LINING	
	DATE	NAME	APPROVED	SCALE	DRAWING NO.	OUTLINE DRAWING	
DRAWN	2014-11-10	J.MAEDA	K.OKAMURA				
CHECKED	2014-11-10	K.OKAMURA					
RENEWAL							
					OLD DWG.NO.	HY516428	
						INDEX	PAGE
							01
							1